

TECHNICAL DATA N° 2.613 - 574953221

LAMP INFO

Description:	LAMP MESA STOIS, LED 8W, touch 3 steps (plata)		
Mark:	20001 TL Table Lamp		
Reference:	574953221		
Provisional Ref.:			
Range:	57495 STOIS		
Code EAN:	8421797749538		
Measures (mm):	0396-0221-0702	Weight (kg):	2.41

TECHNICAL INFO

Lampholder/Watts:	LED 8W	Switch:	Touch	Transformer:	Yes
Bulb included:	Yes	Dimmer:	Yes	Voltage/Frequence:	230V - 50Hz
CCT:	4500K	Efi:	A++..A	Shade:	No
Lm:	-	Ra:	-	Shrink wrap:	No
Class:	II	Bulk:	No	Applied Standard:	CE / LVD
IP:	20	McAdam:	-	Power:	-

PACKAGING DETAILS

	Individual Box	Outer Box	Master Box
Type:	MDC-MARRON / BROWN	MDC - MARRON / BROWN	
Units:	1.00	6.00	0.00
Measures:	0260-0155-0515	0540-0485-0535	___ - ___ - ___
Gross Weight (kg):	3.04	19.50	-
CTN 40':	2.398,00		

OBSERVATIONS

LED 400lm

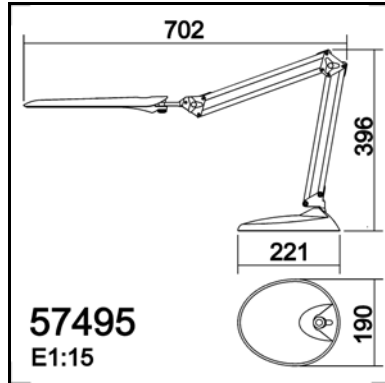

TECHNICAL DATA N° 2.611 -574958021

LAMP INFO

Description:	LAMP MESA STOIS, LED 8W, touch 3 steps (blanco)		
Mark:	20001 TL Table Lamp		
Reference:	574958021		
Provisional Ref.:			
Range:	57495 STOIS		
Code EAN:	8421797749583		
Measures (mm):	0396-0221-0702	Weight (kg):	2.41

TECHNICAL INFO

Lampholder/Watts:	LED 8W	Switch:	Touch	Transformer:	Yes
Bulb included:	Yes	Dimmer:	Yes	Voltage/Frequence:	230V - 50Hz
CCT:	4500K	Efi:	A++..A	Shade:	No
Lm:	-	Ra:	-	Shrink wrap:	No
Class:	II	Bulk:	No	Applied Standard:	CE / LVD
IP:	20	McAdam:	-	Power:	-

PACKAGING DETAILS

	Individual Box	Outer Box	Master Box
Type:	MDC-MARRON / BROWN	MDC - MARRON / BROWN	
Units:	1.00	6.00	0.00
Measures:	0260-0155-0515	0540-0485-0535	___ - ___ - ___
Gross Weight (kg):	3.04	19.50	-
CTN 40':	2.398,00		

OBSERVATIONS

LED 400lm

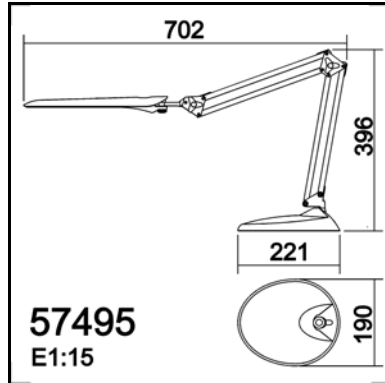

TECHNICAL DATA N° 2.612 -574959021

LAMP INFO

Description:	LAMP MESA STOIS, LED 8W, touch 3 steps (negro)		
Mark:	20001 TL Table Lamp		
Reference:	574959021		
Provisional Ref.:			
Range:	57495 STOIS		
Code EAN:	8421797749590		
Measures (mm):	0396-0221-0702	Weight (kg):	2.41

TECHNICAL INFO

Lampholder/Watts:	LED 8W	Switch:	Touch	Transformer:	Yes
Bulb included:	Yes	Dimmer:	Yes	Voltage/Frequence:	230V - 50Hz
CCT:	4500K	Efi:	A++..A	Shade:	No
Lm:	-	Ra:	-	Shrink wrap:	No
Class:	II	Bulk:	No	Applied Standard:	CE / LVD
IP:	20	McAdam:	-	Power:	-

PACKAGING DETAILS

	Individual Box	Outer Box	Master Box
Type:	MDC-MARRON / BROWN	MDC - MARRON / BROWN	
Units:	1.00	6.00	0.00
Measures:	0260-0155-0515	0540-0485-0535	___ - ___ - ___
Gross Weight (kg):	3.04	19.50	-
CTN 40':	2.398,00		

OBSERVATIONS

LED 400lm